

Application and Design

The Model C-SR-WT is a rectangular UL Classified ceiling (radiation) damper, butterfly style, approved for steel duct, flex duct and ductless installations in approved UL ceiling/floor designs as listed below**. These dampers provide protection up to 18" x 18" openings, or rectangular openings not exceeding 324" sq. inches (with limitations, see sizing chart)

Standard Construction

Frame: Galvanized Steel (gauge as required by UL)

Blades: Galvanized Steel, uninsulated 80 sq. in. and under, sizes over 80 sq. in. insulated with 1/8" kaowool flex wrap non-quilted insulation (gauge as required by UL)

Springs: Corrosion resistant steel spring

Fusible Link: Replaceable 165°F (75°C) std. (212° F optional)

Designed and tested in accordance to standards: UL 555C, ULC S112.2. Labeled and listed by UL/ULC under File# R25411. They meet all the NFPA-90A, IBC Code, and other major code requirements for Ceiling (Radiation) Dampers.

Note: Due to continuing research, UE reserves the right to change specifications without notice.

Standard Sizes (duct)		
Min. Size (W x H)	Max. Size (W x H)	*Inlet size (D)
6" x 4" [152mm x 102mm]	square: 18" x 18" 457mm x 457mm	4"Ø (102mm) min. 12"Ø (305mm) oval equivalent (max.)
	rectangular: 22" w or 20"h with a maximum area of 324 sq. in.	

*Duct connections may be provided as oval equivalent.

**Intended for installation in Fire Resistance Design Nos. L546, L558, L574, L585, M520, P533, P538, P545, P547, & P559 as detailed in the UL Fire Resistance Directory and are similar to fire resistance rated ceiling constructions represented in the International Building Code. Contact factory regarding design nos. not listed above.

SUGGESTED SPECIFICATION

Wood Truss Ceiling damper's shall be Model C-S/R-WT by United Energetech. Ceiling dampers shall bear the Underwriters' Laboratories label and be rated for both steel duct and flex duct installations. No external damper supports shall be required for ceiling dampers up to and including 18" square (457mm). Ceiling dampers shall be non-asbestos type and be furnished with a fusible link. Volume controller furnished where shown.

Manufacturer's Recommendations

All moving parts of the damper must be inspected and cycled once the first year and at intervals not greater than every 4 years or in accordance with the latest edition of NFPA 90A, 92A, and local codes. In addition, fuse links shall be removed and inspected for corrosion. Dry lubricants are recommended.

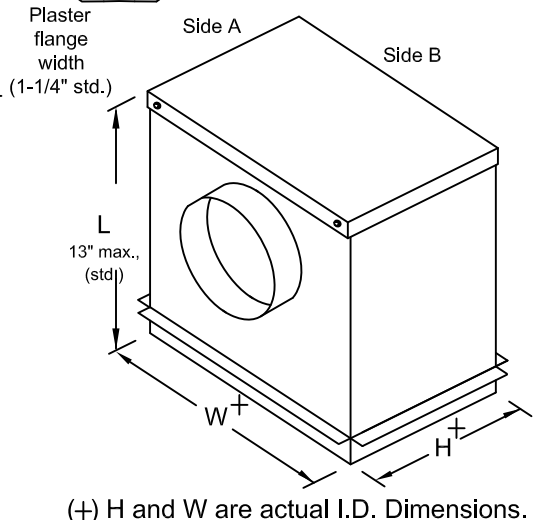
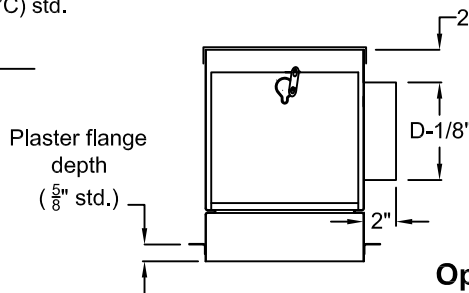
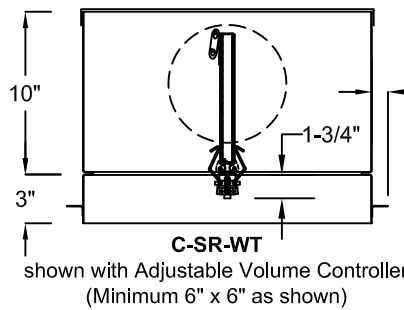

UL approved with steel and aluminum diffuser

Options:

- Volume Adjustment (min. size: 6"x6")
- Boot Rail
- Inlet Connection
 - Round/Oval Equivalent Square/Rectangular
 - Side: A B
- Alternate Plaster Flange
 - 1-1/4" deep x 1-1/4" wide
 - 2" deep x 1-1/4" wide 3" deep x 1-1/4" wide
- Alternate 212° F (100°C) fusible link

Job Name:	<input type="checkbox"/> MODEL C-SR-WT (Butterfly Damper)		
Location:			
Architect:			
Engineer:	DRAWN BY: CLJ	DATE: 4-6-14	REV. DATE: 7-28-16
Contractor:	REV. NO. 5	APPROVED BY: BGT	DWG. NO.: P-93a